

DETAIL 1

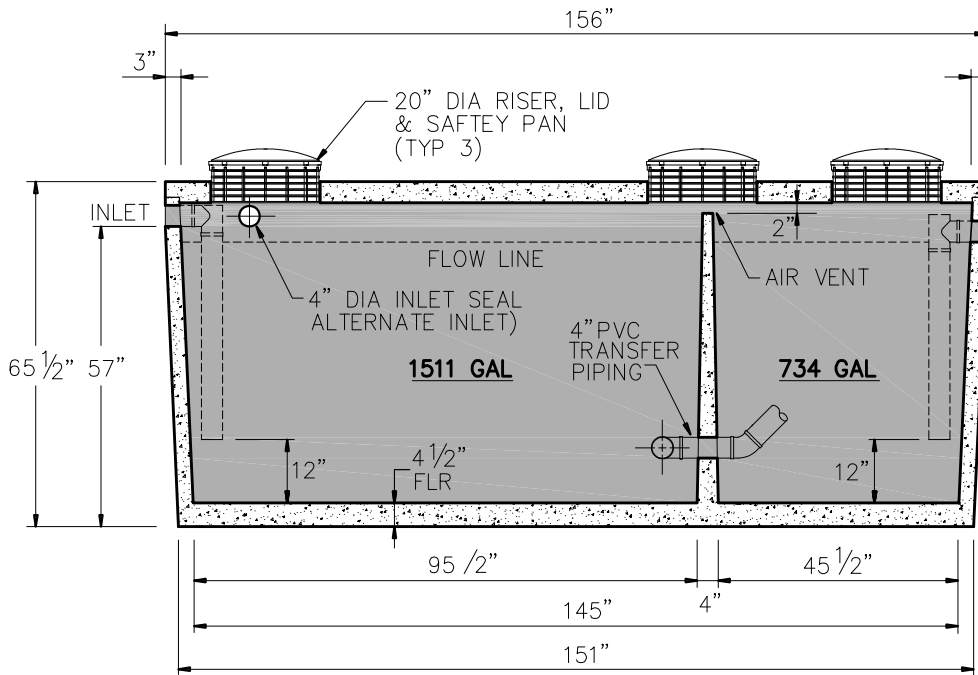

SECTION A-A

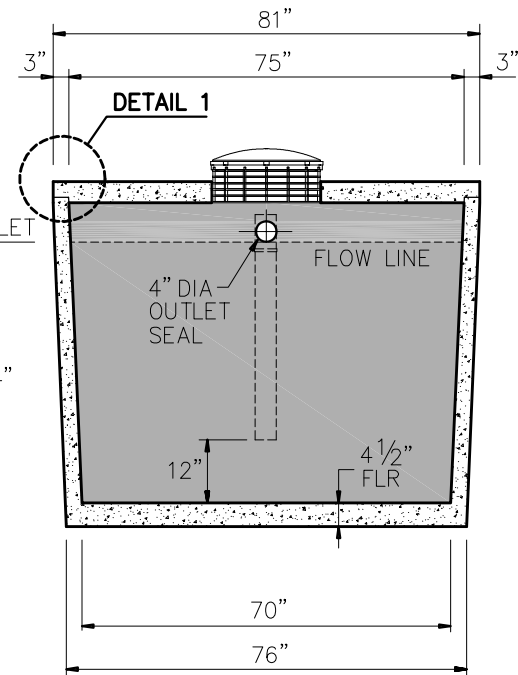

SECTION B-B

NOTE: INLET/OUTLET PVC PIPING TO BE SUPPLIED BY CUSTOMER

GENERAL NOTES:

- DESIGN SHALL MEET OR EXCEED ASTM C-1227 SPECIFICATIONS
- 4000 PSI CONCRETE AT 28 DAYS
- ASTM A615, GRADE 60 REINFORCING
- BAR BENDING AND PLACEMENT PER ACI STANDARDS

- * RECOMMENDED FOR OSSF USE
- * NOT FOR USE IN TRAFFIC LOADING

Gals.	Grease Lbs.	Weight	Flow Rate GPM	
			Avg	Peak
2000	5,400	16,360	15.3	38.3



9235 Main Street #1
P.O. Box 507
Needville, Texas, 77461
1-888-331-5871

"Providing Concrete Environmental Solutions"

2000 GALLON
COMMERCIAL GREASE TRAP
LIGHT DUTY LOADING

NC-005-026

Scale: N.T.S.
* All Dimensions subject to allowable specification tolerances.

Date: 05/30/24

Rev Date:

Approved By: _____ Date: _____