

3" ADJUSTMENT RING (AS REQ.)
WEIGHT - 145 LBS

CAST IRON RING & COVER
(PER CUSTOMER SPECS.)

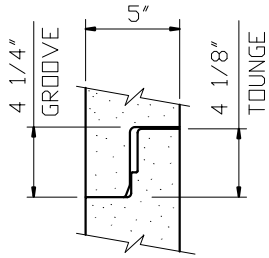

48" JOINT DETAIL

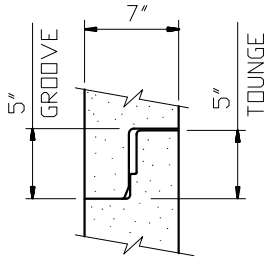

72" JOINT DETAIL

NOTE:
72" DIA. SLAB TOP AVAILABLE
AS REQUIRED.
(WEIGHT - 4800 LBS.)

NOTE:
PLEASE REFER TO NC PIPE
FOR ALL PRECAST BASE
HEIGHTS AND WEIGHTS.

GENERAL NOTES:

- DESIGN SHALL MEET OR EXCEED ASTM C-478 SPECIFICATIONS
- 4500 PSI CONCRETE AT 28 DAYS
- ATSM A615, GRADE 60 REINFORCING
- HS 20 LOADING
- JOINT CONNECTIONS TO BE GASKETS CONFORMING TO ASTM C-443 REQUIREMENTS

OPTIONAL COATINGS & ADMIXTURES AVAILABLE:

- FE-100 THANE COAT
- BITUMASTIC
- XYPEX
- CONSHIELD

DOGHOUSE
OPENING
SIZE & LOCATION
AS REQUIRED.

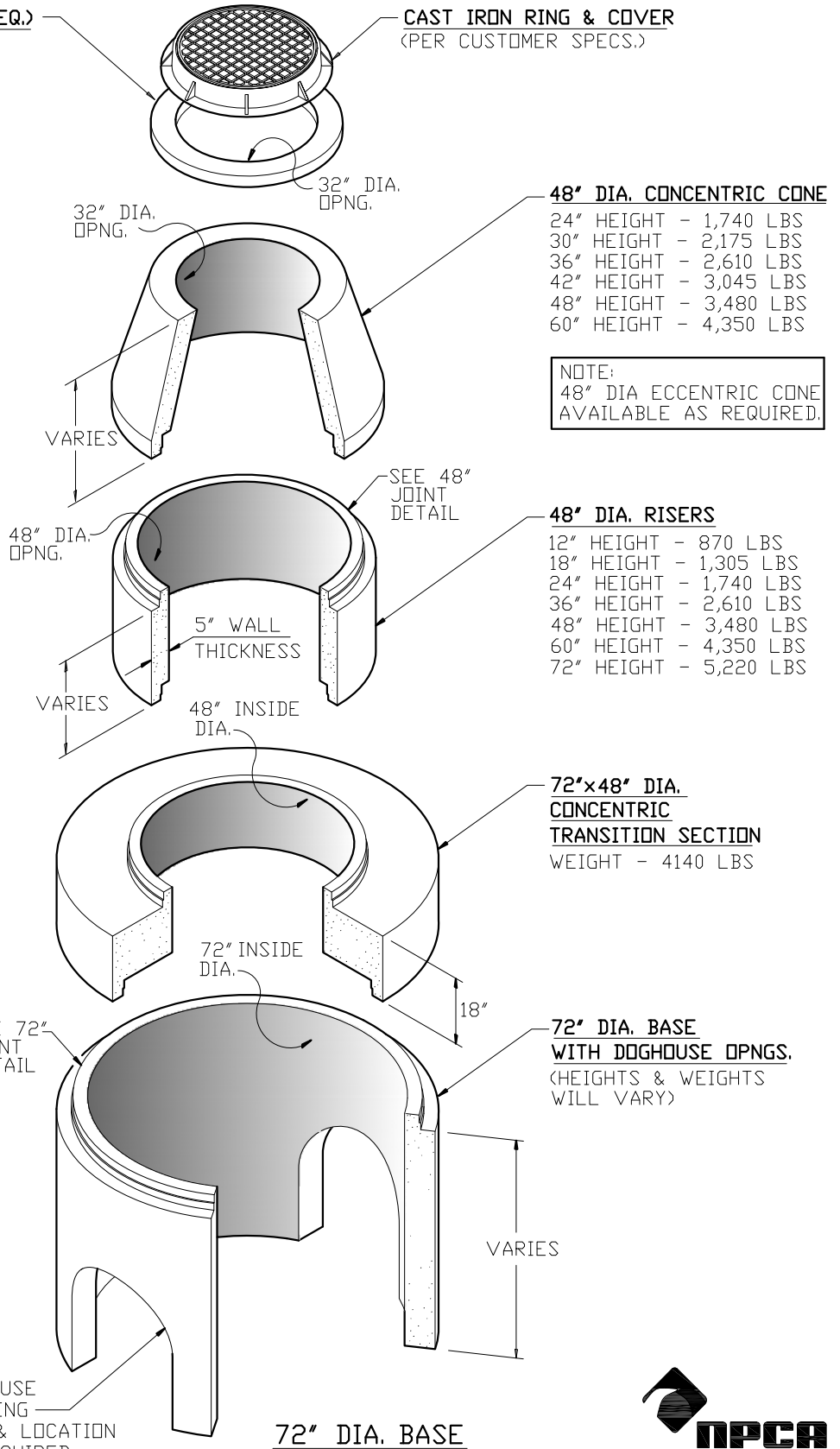

48" DIA. CONCENTRIC CONE
24" HEIGHT - 1,740 LBS
30" HEIGHT - 2,175 LBS
36" HEIGHT - 2,610 LBS
42" HEIGHT - 3,045 LBS
48" HEIGHT - 3,480 LBS
60" HEIGHT - 4,350 LBS

NOTE:
48" DIA ECCENTRIC CONE
AVAILABLE AS REQUIRED.

48" DIA. RISERS
12" HEIGHT - 870 LBS
18" HEIGHT - 1,305 LBS
24" HEIGHT - 1,740 LBS
36" HEIGHT - 2,610 LBS
48" HEIGHT - 3,480 LBS
60" HEIGHT - 4,350 LBS
72" HEIGHT - 5,220 LBS

**72"x48" DIA. CONCENTRIC
TRANSITION SECTION**
WEIGHT - 4140 LBS

**72" DIA. BASE
WITH DOGHOUSE OPNGS.**
(HEIGHTS & WEIGHTS
WILL VARY)

72" DIA. BASE



9235 Main Street #1
P.O. Box 507
Needville, Texas, 77461
1-888-331-5871

"Providing Concrete Environmental Solutions"

72" DIA. DOGHOUSE
MANHOLE

NC-001-014

Scale: 1/4"=1'-0"
* All Dimensions subject to allowable
specification tolerances.

Date: 03/28/18

Approved By: _____ Date: _____