

CAST IRON ASTM A-48 CLASS 30B

NOTE:  
(OPTIONAL)  
CAST IRON ADA GRATE & SOLID  
COVER AVAILABLE

NOTE:  
ADDITIONAL FRAME & GRATE SIZES  
AVAILABLE

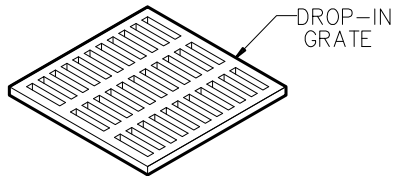

**CAST IRON GRATE**

**38" X 38"**

OPEN AREA - 631 SQ/IN  
WEIGHT - 470 LBS

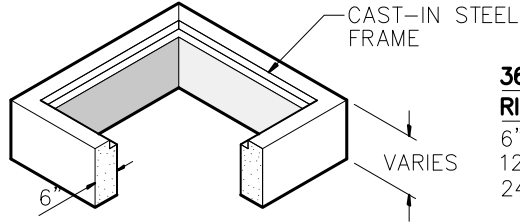

**36" X 36" I.D.**

**RISER SECTION (OPTIONAL)**

6" HEIGHT - 525 LBS  
12" HEIGHT - 1050 LBS  
24" HEIGHT - 2100 LBS

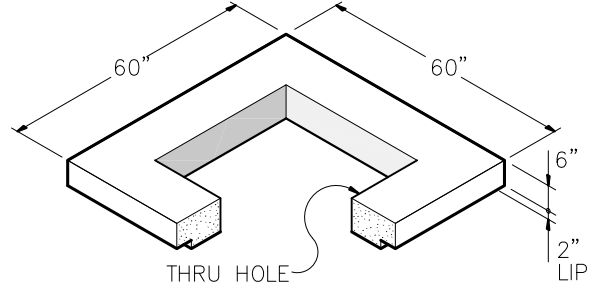
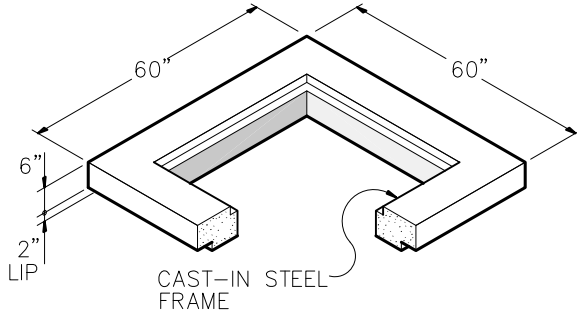

**SLAB TOP W/  
CAST IN STEEL FRAME**  
WEIGHT - 2050 LBS

**REINFORCEMENT (SLAB TOP)**  
#4 BARS @ PERIMETER OF  
THRU HOLE  
#4 BARS @ 6" O.C.E.W.

**SLAB TOP W/  
W/ 36" X 36" OPENING  
(OPTIONAL)**  
WEIGHT - 2050 LBS

**REINFORCEMENT (SLAB TOP)**  
#4 BARS @ PERIMETER OF  
THRU HOLE  
#4 BARS @ 6" O.C.E.W.

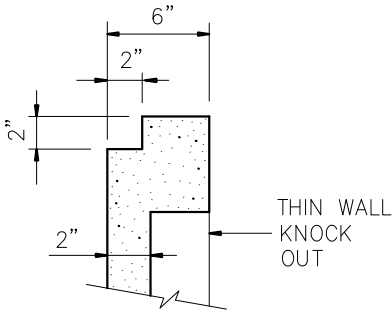

NOTE:  
OPTIONAL BOX RISER AVAILABLE

**TYP. WALL DETAIL**  
**48" X 48"**

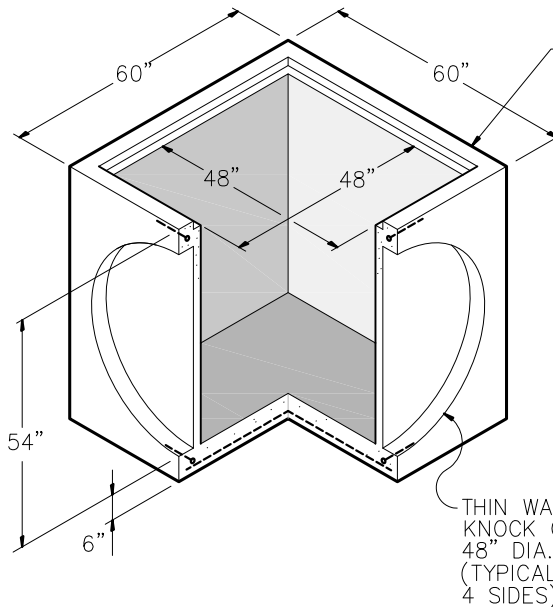

SEE TYP.  
WALL DETAIL

**BASE SECTION**

**48" X 48" I.D.**

WEIGHT - 7730 LBS

**REINFORCEMENT (BASE)**

#4 BARS AROUND PERIMETER  
OF BASE  
#4 BARS @ 12" O.C.E.W. FLOOR

**GENERAL NOTES:**

- DESIGN SHALL MEET OR EXCEED EXCEED ASTM C-913 SPECIFICATIONS
- 4500 PSI CONCRETE AT 28 DAYS
- ATSM A615, GRADE 60 REINFORCING
- HS 20 LOADING
- ALL JOINT CONNECTIONS TO BE GROUTED PER SPECS.



9235 Main Street #1  
P.O. Box 507  
Needville, Texas, 77461  
1-888-331-5871

"Providing Concrete Environmental Solutions"

**48" X 48"**  
**CATCH BASIN**

NC-003-008

Scale: 3/8"=1'-0"  
\* All Dimensions subject to allowable specification tolerances.

Date: 04/22/18

Rev Date: 10/18/18

Approved By: \_\_\_\_\_ Date: \_\_\_\_\_