

CAST IRON ASTM A-48 CLASS 30B

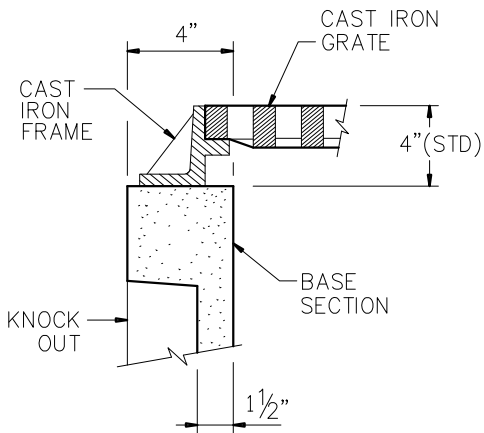

TYP WALL SECTION

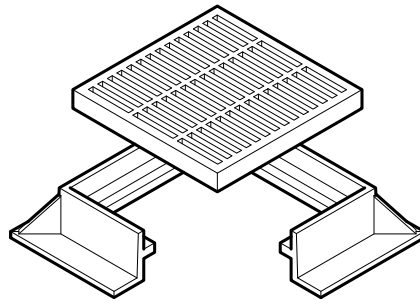

CAST IRON FRAME & GRATE

V5613 OR EQ
 OPEN AREA - 63 SQ/FT
 WEIGHT - 125 LBS
 (FRAME & GRATE)

NOTE:
 FRAME & GRATE FURNISHED
 LOOSE FOR PAVING AREA

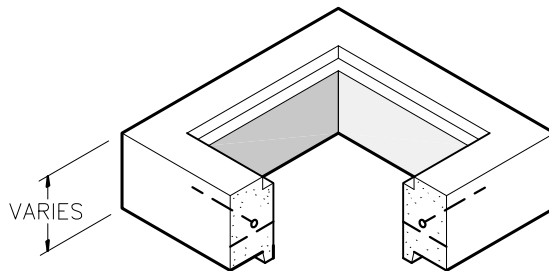

RISER SECTION (OPTIONAL)

6" HEIGHT - 135 LBS
 12" HEIGHT - 270 LBS

REINFORCEMENT (RISER)

#4 BAR @ 6" O.C.E.W.

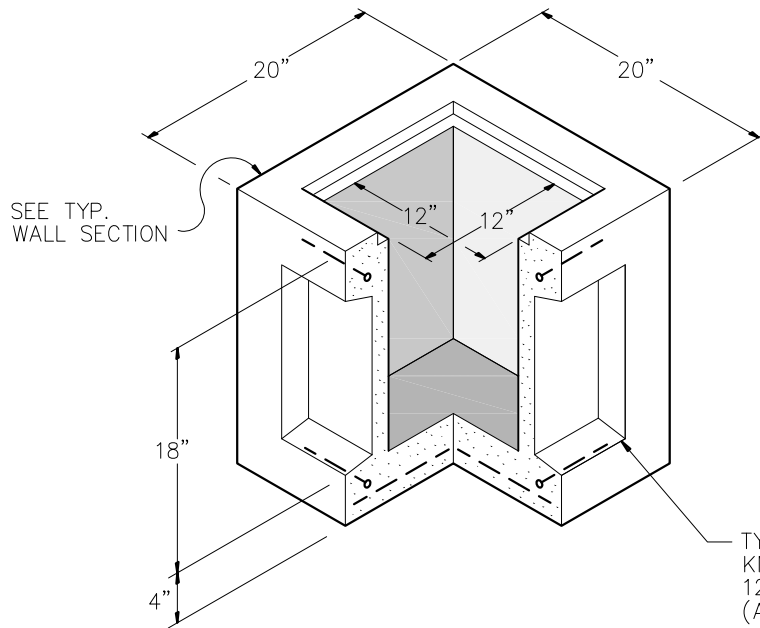

BASE SECTION

WEIGHT - 310 LBS

REINFORCEMENT (BASE)

#4 BARS AROUND PERIMETER
 OF BASE
 #4 BARS @ 12" O.C.E.W. FLOOR

GENERAL NOTES:

- DESIGN SHALL MEET OR EXCEED ASTM C-913 SPECIFICATIONS.
- 4500 PSI CONCRETE AT 28 DAYS
- ATSM A615, GRADE 60 REINFORCING
- H-20 LOADING
- ALL PIPE & JOINT CONNECTIONS TO BE GROUTED PER SPECIFICATIONS.



9235 Main Street #1
 P.O. Box 507
 Needville, Texas, 77461
 1-888-331-5871

"Providing Concrete Environmental Solutions"

TYPE 'A' INLET
 12" X 12"
 V5600 SERIES

NC-003-011

Scale: 3/4"=1'-0"
 * All Dimensions subject to allowable specification tolerances.

Date: 03/19/18

Rev Date: 10/18/18

Approved By: _____ Date: _____