

**NARROW SLOT
GRATE (OPTIONAL)**

V4880-3 OR EQ.
OPEN AREA - 442 SQ/IN
WEIGHT - 195 LBS

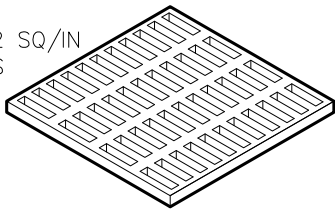

CAST IRON ASTM A-48 CLASS 30B

**30" X 30"
CAST IRON GRATE**

V4880-1 OR EQ. (STD)
OPEN AREA - 473 SQ/IN
WEIGHT - 190 LBS

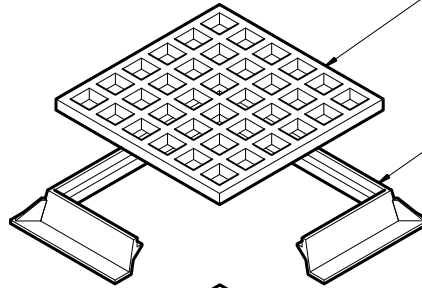

CAST IRON FRAME

V4880 OR EQ.
WEIGHT - 235 LBS

NOTE:
FRAME & GRATE FURNISHED
LOOSE FOR PAVING AREA

ADA GRATE (OPTIONAL)

V4880-ADA OR EQ.
OPEN AREA - 283 SQ/IN
WEIGHT - 235 LBS

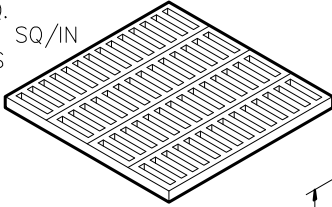

SOLID COVER (OPTIONAL)

WEIGHT - 195 LBS

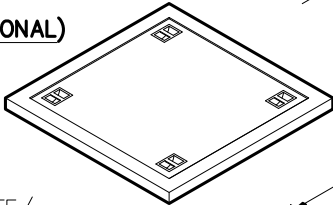

RISER SECTION (OPTIONAL)

6" HEIGHT - 475 LBS
12" HEIGHT - 950 LBS
24" HEIGHT - 1900 LBS
36" HEIGHT - 2850 LBS

REINFORCEMENT (RISER)

#4 BAR @ 6" O.C.E.W.

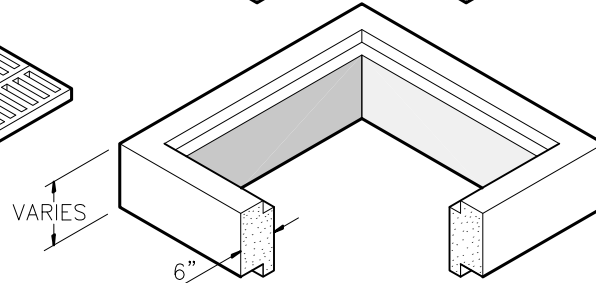

**36" X 36" SLAB TOP
W/ 30" X 30" OPENING**

WEIGHT - 560 LBS

REINFORCEMENT (SLAB TOP)

#4 BARS @ PERIMETER OF
THRU HOLE
#4 BARS @ 6" O.C.E.W.

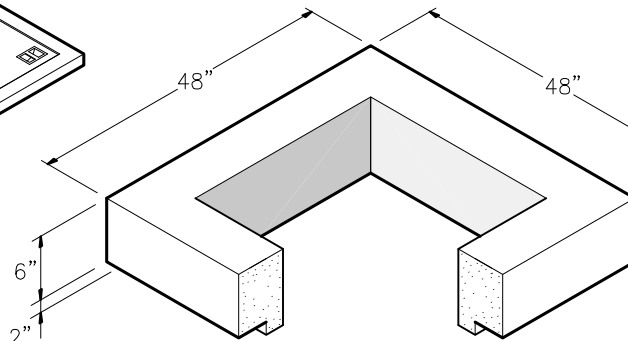

SEE TYP.
WALL SECTION

BASE SECTION

36" X 36"
36" HEIGHT - 4350 LBS
42" HEIGHT - 4675 LBS
(STD. HT.)
48" HEIGHT - 5400 LBS

REINFORCEMENT (BASE)

#4 BARS AROUND PERIMETER
OF BASE
#4 BARS @ 12" O.C.E.W. FLR.

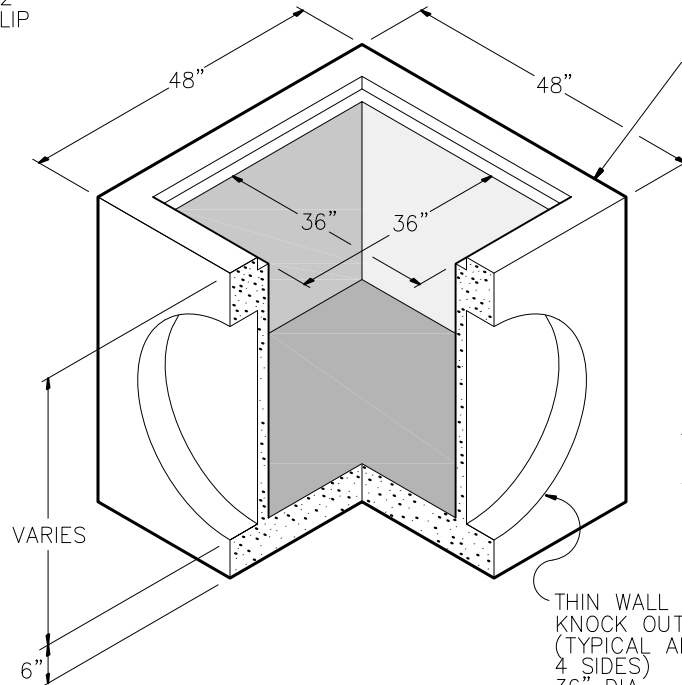

THIN WALL
KNOCK OUT
(TYPICAL ALL
4 SIDES)
36" DIA.

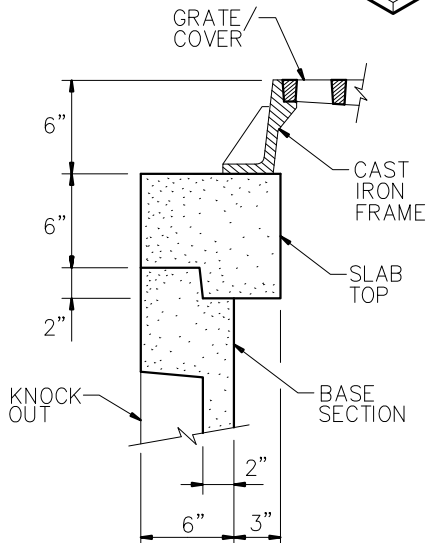

TYPICAL WALL SECTION

GENERAL NOTES:

- DESIGN SHALL MEET OR EXCEED ASTM C-913 SPECIFICATIONS.
- 4500 PSI CONCRETE AT 28 DAYS
- ATSM A615, GRADE 60 REINFORCING
- H-20 LOADING
- ALL PIPE & JOINT CONNECTIONS TO BE GROUTED PER SPECIFICATIONS.



9235 Main Street #1
P.O. Box 507
Needville, Texas, 77461
1-888-331-5871

"Providing Concrete Environmental Solutions"

TYPE 'A' INLET
36" X 36"

NC-003-015

Scale: 1"=1'-0"
* All Dimensions subject to
allowable specification tolerances.

Date: 04/22/18

Rev Date: 10/18/18

Approved By: _____ Date: _____