

**NARROW SLOT
GRATE (OPTIONAL)**

V4880-3 OR EQ.
OPEN AREA - 442 SQ/IN
WEIGHT - 195 LBS

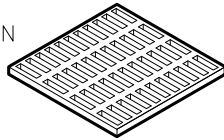

ADA GRATE (OPTIONAL)

V4880-ADA OR EQ.
OPEN AREA - 283 SQ/IN
WEIGHT - 235 LBS

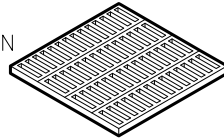

SOLID COVER (OPTIONAL)

WEIGHT - 195 LBS

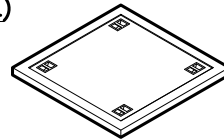

CAST IRON ASTM A-48 CLASS 30B

**30" X 30"
CAST IRON GRATE**

V4880-1 OR EQ. (STD)
OPEN AREA - 473 SQ/IN
WEIGHT - 190 LBS

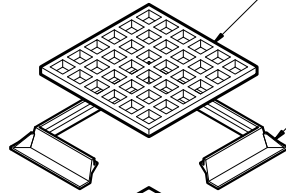

CAST IRON FRAME

V4880 OR EQ.
WEIGHT - 235 LBS

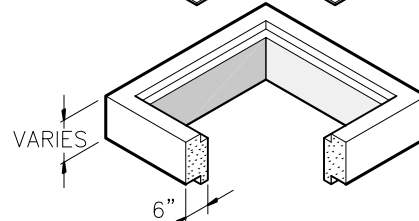

NOTE:
FRAME & GRATE FURNISHED
LOOSE FOR PAVING AREA

RISER SECTION (OPTIONAL)

6" HEIGHT - 475 LBS
12" HEIGHT - 950 LBS
24" HEIGHT - 1900 LBS
36" HEIGHT - 2850 LBS

REINFORCEMENT (RISER)

#4 BAR @ 6" O.C.E.W.

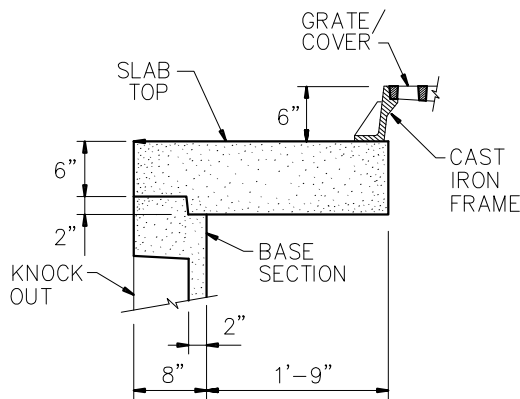

TYPICAL WALL SECTION

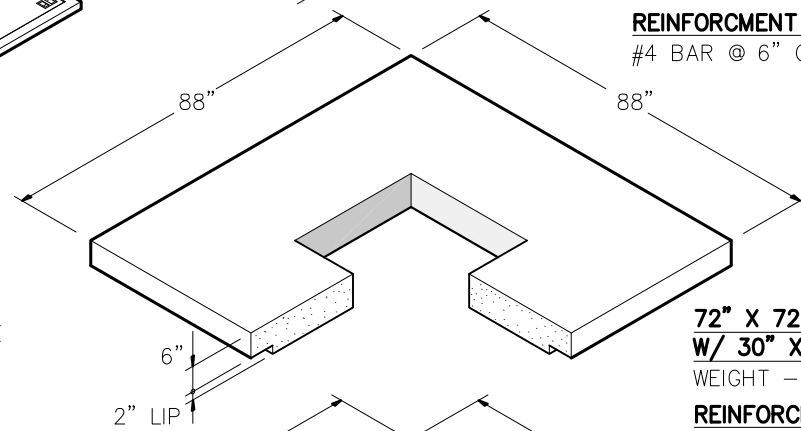

**72" X 72" SLAB TOP
W/ 30" X 30" OPENING**

WEIGHT - 4400 LBS

REINFORCEMENT (SLAB TOP)

#5 BARS @ PERIMETER OF
THRU HOLE
#5 BARS @ 6" O.C.E.W.

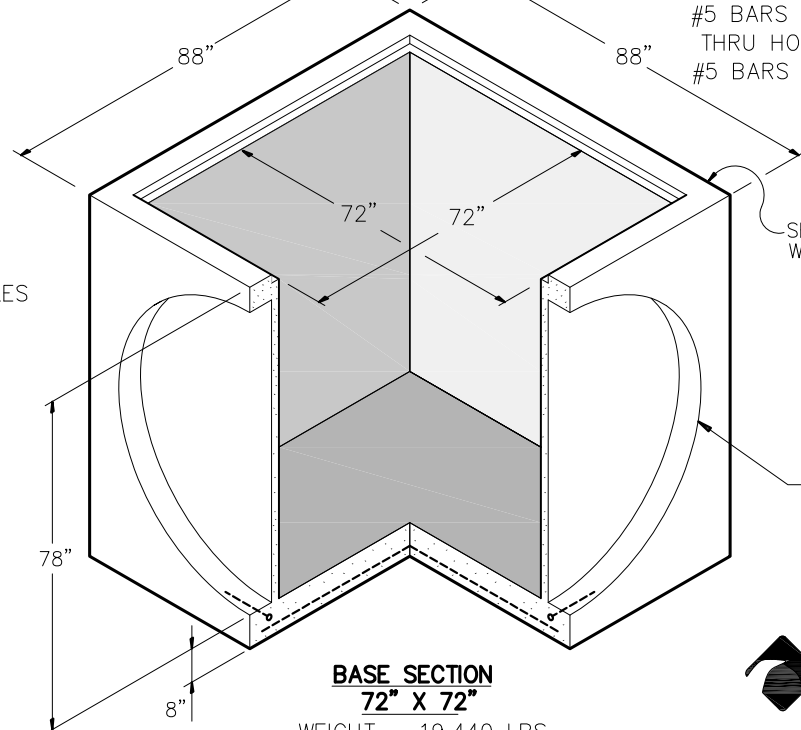

**BASE SECTION
72" X 72"**

WEIGHT - 19,440 LBS

REINFORCEMENT (BASE)

#5 BARS AROUND PERIMETER OF THRU HOLES
#5 BARS @ 12" O.C.E.W. - FLOOR

NOTE:
PLEASE REFER TO NC PIPE
FOR ALL PRECAST BASE
HEIGHTS & WEIGHTS

GENERAL NOTES:

- DESIGN SHALL MEET OR EXCEED ASTM C-913 SPECIFICATIONS.
- 4500 PSI CONCRETE AT 28 DAYS
- ATSM A615, GRADE 60 REINFORCING
- H-20 LOADING
- ALL JOINT CONNECTIONS TO BE GROUTED PER SPECIFICATIONS.



9235 Main Street #1
P.O. Box 507
Needville, Texas, 77461
1-888-331-5871

"Providing Concrete Environmental Solutions"

TYPE 'A' INLET
72" X 72"

NC-003-018

Scale: 3/8"=1'-0"
* All Dimensions subject to allowable specification tolerances.

Date: 04/22/18

Rev Date: 10/18/18

Approved By: _____ Date: _____